



ALL AXIS FLOOR: HAAS CNC, UNIVERSAL ROBOT ARM, MAKERBOT METHOD

ALL AXIS ROBOTICS

Printing end of arm effectors

ABOUT THE PROJECT

This custom dual-grit robot sander attachment was designed and manufactured in-house by All Axis engineers in under two weeks using a MakerBot METHOD X 3D printer with strong and durable real ABS material. The robot sander automates the time-consuming manual aluminum sanding operation, helping a machine shop to run more efficiently by freeing up personnel for other tasks. It features two sides with different grid sand pads as well as a connection for a vacuum to remove debris.

KEY TAKEAWAYS

- Tooling for robotic arms requires tight tolerances close to ± 0.007 in (± 0.2 mm) and hole cylindricity for optimal fit and function.
- Large overhangs, carve-outs, and other complex part features are near-impossible to machine, requiring Stratasys® SR-30 soluble support material.
- All Axis was able to create their part using production-grade ABS.

ABOUT ALL AXIS

All Axis Robotics is a Dallas, Texas-based machine shop and a leader in turnkey custom robot solutions for other machine shops and manufacturing facilities in need of automated machine tending. Customers enlist the expertise of All Axis Robotics' mechanical and manufacturing engineers to streamline their manufacturing operations with robotic arms and custom end-effectors including those for CNC machine tending, automated part sanding, and brake press machine tending, among others.

ROBOTIC SANDER

SIZE	17cm x 15.1cm x 13.7cm
VOLUME	410 cm ³
CAD TO PART	66h 15m
PART COST	\$110 USD
PRINTED ON	METHOD X
MODEL MATERIAL	MakerBot ABS
SUPPORT MATERIAL	Stratasys® SR-30

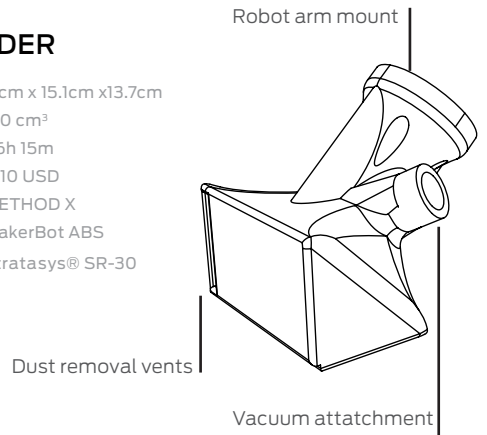

ALL AXIS PROCESS

The engineering team at All Axis used METHOD X to produce custom tooling with approximately 10 minutes of labor time and at an operational cost of \$110—compared to 24 hours of labor time at an operational cost of \$3,600 with an in-house CNC machine.

This ability to create custom solutions for customers—combined with rapid turnaround times—has helped All Axis gain a competitive advantage against competitors as more manufacturing facilities upgrade new and legacy equipment to meet the increasing demands of industry 4.0 and the modern global marketplace.

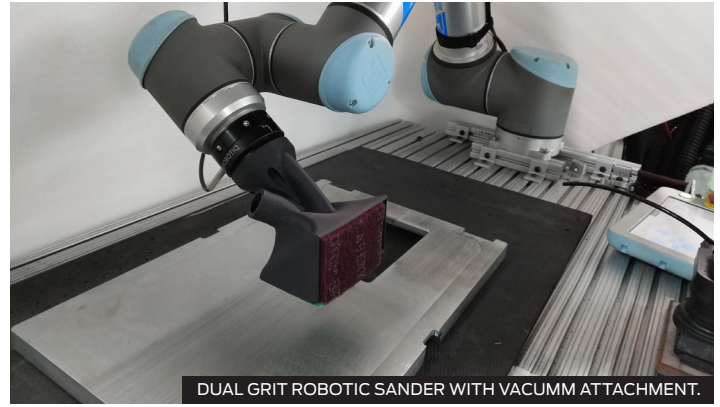

DUAL GRIT ROBOTIC SANDER WITH VACUUM ATTACHMENT.







ALL AXIS AND MAKERBOT METHOD

By producing the part with an in-house METHOD 3D printer, the team was able to eliminate undesirable factors typical of traditional manufacturing processes, including expensive machinist time and material costs. And by approaching the part design through the lens of freeform additive manufacturing, the engineers were able to 3D model the part quickly without having to account for complex assembly considerations typical of traditional manufacturing processes.

The ability to print with soluble Stratasys® SR-30 supports allowed the engineers to design the sander as one complex part, which would've been impossible to machine. METHOD's dimensional accuracy ensured that the part mated perfectly with the robot arm on the first try. The use of production-grade Real ABS printed in a heated chamber produced a very strong and durable tool that is built to last.



ALL AXIS FLOOR: DMG MORI CNC, MAKERBOT METHOD.

	IN HOUSE CNC	METHOD
 MATERIAL	Aluminum	ABS / Stratasys® SR-30
 DIGITAL PREPARATION	8 hours (CAM programming)	5 minutes (slicing)
 MATERIAL PREPARATION	16 hr (blank preparation, fixturing)	5 minutes (material loading)
 RUN TIME	12 hours	44 hours
 TOTAL LABOR TIME	▲ 24 hours	▼ 10 minutes
 TOTAL COST	▲ \$3,600 USD	▼ \$110 USD

METHOD

A MANUFACTURING WORKSTATION.

Print real ABS with 100 C Heated Chamber.

Powered by:  stratasys

MakerBot METHOD bridges the gap between industrial and desktop 3D printing. It was developed from the ground up leveraging industry-leading Stratasys® patents including a heated build chamber, precision dissolvable supports, and dry-sealed material bays. Engineers and designers use METHOD to create prototypes, jigs and fixtures, and end-use parts.